

16 Male J.I.C. (37°) X Female J.I.C. (37°)

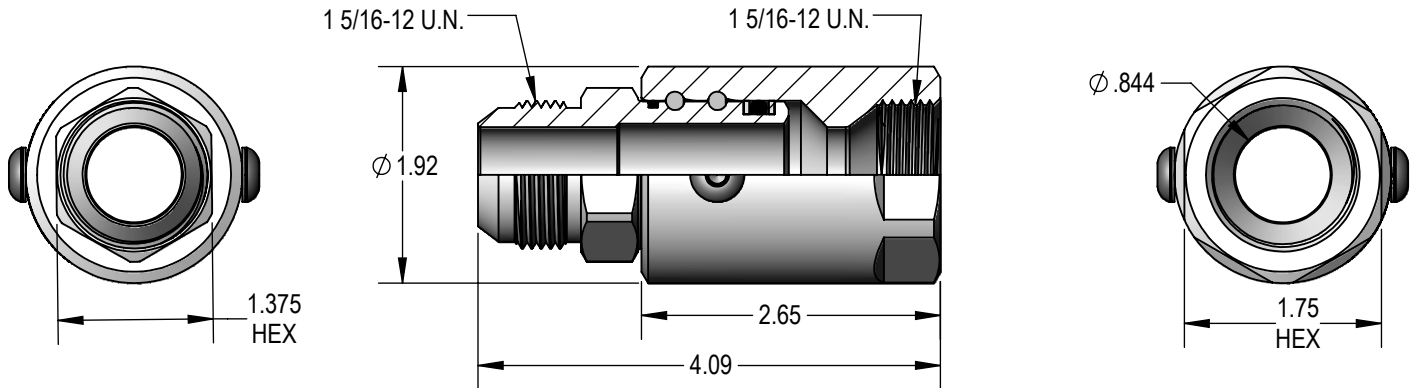

PART NUMBER
SS 16 DB MJ 16 X FJ 16

MAXIMUM P.S.I.G.
4,500

Not Available
 In Stainless Steel!

*Extra Heavy Duty
 Multiple Bearing Race*



16 Male J.I.C. (37°) X Male J.I.C. (37°)

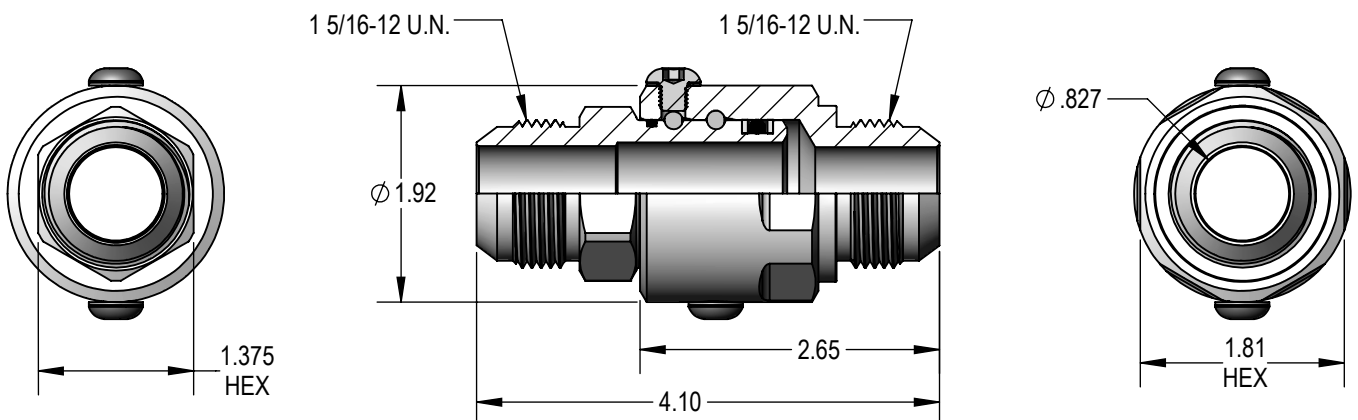

PART NUMBER
SS 16 DB MJ 16 X MJ 16

MAXIMUM P.S.I.G.
4,500

Not Available
 In Stainless Steel!