

16 Male J.I.C. (37°) X Female O-Ring (O.R.B.)

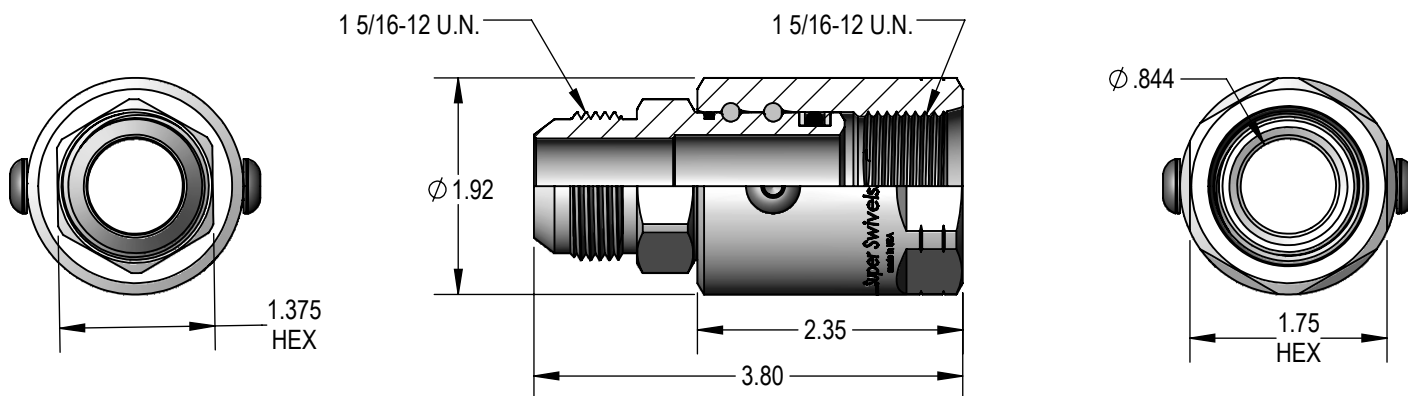

PART NUMBER
SS 16 DB MJ 16 X FO 16

MAXIMUM P.S.I.G.
4,500

Not Available
In Stainless Steel!

*Extra Heavy Duty
Multiple Bearing Race*



16 Male O-Ring (O.R.B.) X Female O-Ring (O.R.B.)

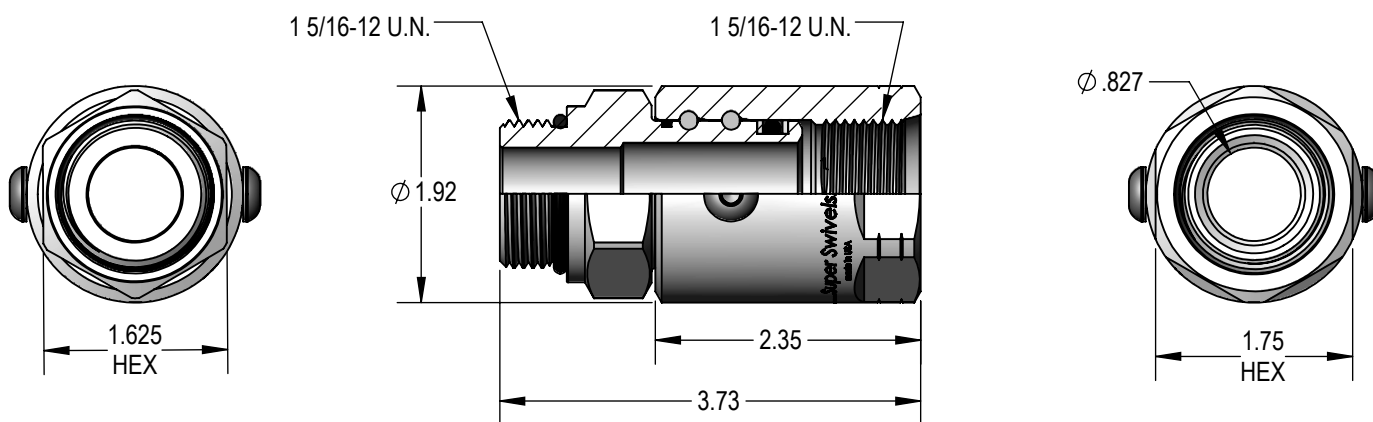

PART NUMBER
SS 16 DB MO 16 X FO 16

MAXIMUM P.S.I.G.
4,500

Not Available
In Stainless Steel!